

NUMERICAL STUDY ON THE INFLUENCE OF DIFFERENT BOUNDARY CONDITIONS ON THE EFFICIENCY OF HYDROGEN RECOMBINERS INSIDE A CAR GARAGE

J. Baggemann¹, W. Jahn¹, S. Kelm¹, E.-A. Reinecke^{1,*}, H.-J. Allelein^{1,2}

¹Institute of Energy and Climate Research – Reactor Safety
Forschungszentrum Jülich GmbH
52425 Jülich, Germany
e.reinecke@fz-juelich.de

²Institute of Reactor Safety and Reactor Technology
RWTH Aachen University
52062, Aachen, Germany

ABSTRACT

Passive auto-catalytic recombiners (PARs) have the potential to be used in the future for the removal of accidentally released hydrogen inside confined areas. PARs could be operated both as stand-alone or backup safety devices, e.g. in case of active ventilation failure.

Recently, computational fluid dynamics (CFD) simulations have been performed in order to demonstrate the principal performance of a PAR during a postulated hydrogen release inside a car garage. This fundamental study has now been extended towards a variation of several boundary conditions including PAR location, hydrogen release scenario, and active venting operation. The goal of this enhanced study is to investigate the sensitivity of the PAR operational behavior for changing boundary conditions, and to support the identification of a suitable PAR positioning strategy. For the simulation of PAR operation, the in-house code REKO-DIREKT has been implemented in the CFD code ANSYS-CFX 15.

In a first step, the vertical position of the PAR and the thermal boundary conditions of the garage walls have been modified. In a subsequent step, different hydrogen release modes have been simulated, which result either in a hydrogen-rich layer underneath the ceiling or in a homogeneous hydrogen distribution inside the garage. Furthermore, the interaction of active venting and PAR operation has been investigated.

As a result of this parameter study, the optimum PAR location was identified to be close underneath the garage ceiling. In case of active venting failure, the PAR efficiently reduces the flammable gas volume (hydrogen concentration > 4 vol.%) for both stratified and homogeneous distribution. However, the simulations indicate that the simultaneous operation of active venting and PAR may in some cases reduce the overall efficiency of hydrogen removal. Consequently, a well-matched arrangement of both safety systems is required in order to optimize the overall efficiency. The presented CFD-based approach is an appropriate tool to support the assessment of the efficiency of PAR application for plant design and safety considerations with regard to the use of hydrogen in confined areas.

1.0 INTRODUCTION

Hydrogen may be used in the future as energy carrier in a large variety of different applications and boundary conditions. The prevention of flammable mixtures of hydrogen with air represents the most important safety consideration for any of these applications. Broad experience with the safe handling of hydrogen at a large industrial scale has been achieved in the past decades. However, the use of hydrogen in an increasing number of applications will pose new challenges to safety. Especially for applications inside closed areas, hydrogen leakages into air-filled confinements may lead to the formation of ignitable mixtures which might cause structural failure and endanger human lives [1].

In order to support safe handling of hydrogen and to limit the consequence of accidents related to hydrogen, JÜLICH is focusing on the simulation of hydrogen release scenarios taking into account mitigation measures and strategies. For this purpose, an integrated approach for simulating the full sequence of accident phenomena relevant for the assessment of mitigation strategies is developed based on the use of CFD codes. Modeling approach and validation strategy for the simulation of hydrogen release scenarios and mitigation have been described in [2]. One of the specific research areas involves the operation of passive auto-catalytic recombiners.

Passive auto-catalytic recombiners (PARs) have the potential to be used in the future as mitigation devices inside confined areas for the conversion of accidentally released hydrogen into water. PARs are passive safety devices without the need of external power supply and could be operated both as stand-alone application or backup safety devices, e.g. in case of active ventilation failure. Today, due to their passive operation PARs are used inside the containments of nuclear power plants in many countries in order to remove hydrogen generated during specific reactor accident scenarios [3]. Due to their ability to convert hydrogen and oxygen into water already at low (ambient) temperature, PARs provide a hydrogen sink even in situations where dilution and venting is limited or impossible.

The working principle of a PAR is illustrated in Fig. 1. Inside the catalyst section, catalyst sheets form a set of parallel vertical flow channels. On the catalyst surface, hydrogen entering the PAR is converted with oxygen to water. Due to the exothermal reaction, a buoyancy-driven flow is induced inside the chimney surrounding the catalyst section. The chimney ensures an upward gaseous flow through the PAR which automatically feeds the surrounding hydrogen/air mixture into the catalyst section. PARs have undergone a comprehensive qualification program for application in nuclear power plants. Nevertheless, for use in different application fields, optimization potential exists in terms of optimum hydrogen conversion rates, ignition protection, and robustness of the catalyst against poisoning and similar deactivation effects depending on the atmospheric boundary conditions of the application [4].

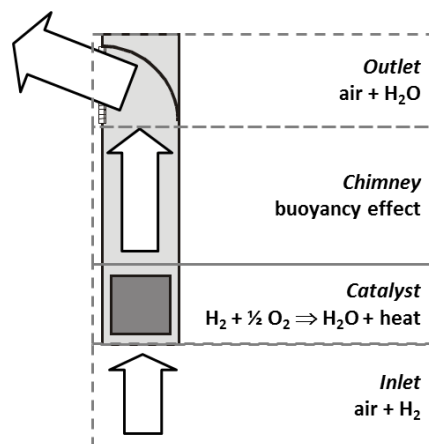

Figure 1: Principle of passive auto-catalytic recombiners (PAR)

In an earlier numerical study [5], the efficiency of the application of a PAR inside a car garage for hydrogen removal from a small leak has been studied. The goal was to estimate whether a PAR designed for operation under the thermal hydraulic conditions inside an NPP containment would operate efficiently inside a realistic environment for hydrogen or fuel cell applications. The simulation results show that the PAR works efficiently by removing hydrogen and promoting mixing inside the garage. This fundamental study has now been extended towards a variation of several boundary conditions including PAR position, hydrogen release scenarios and the interaction with active venting. The goal of the present study is to investigate the sensitivity of the PAR operational behavior for changing boundary conditions in order to support the assessment of the efficiency of PAR application for plant design and safety considerations with regard to the use of hydrogen in confined areas.

2.0 MODELLING APPROACH

Gas distribution of accidentally released hydrogen is driven initially by the release momentum but mostly by the buoyancy of the hydrogen-rich gas. These transport and mixing processes are simulated by applying models available in the commercial CFD package ANSYS CFX [6]. In general, a U-RANS approach, capable to be scaled up and to be applied to technical scale is used. The fundamental modeling approach is based on the Shear Stress Transport (SST) turbulence model including additional terms in the k and ω equation for the production and dissipation of turbulence due to buoyancy. Dependent on the scenario, different heat transfer mechanisms, such as conjugate heat transfer and thermal radiation can be included. The approach has been widely validated in the frame of different projects or benchmark activities [7-10] which are mainly related to nuclear safety issues. An overview on the model development and validation strategy is given by Jaekel et al. [2]. Modeling and in particular validation is performed under consideration of well-known best-practice guidelines, e.g. ERCOFTAC [11] or ECORA [12] in order to minimize numerical errors.

The in-house code REKO-DIREKT is used to describe all relevant aspects of the operational behavior of PARs [13]. The code calculates not only the conditions at the PAR outlet (i.e. gas temperature and concentrations, mass flow) but also the local catalyst temperature and local gas concentrations along the catalyst sheets inside the PAR. The only input parameters required for the calculation are temperature and gas composition at the PAR inlet and the absolute pressure. The model is coupled by means of a data and program flow controlled interface routine to CFX [5]. The stand-alone version of REKO-DIREKT as well as the coupling to CFX have been extensively validated against experimental data [14, 15].

The basic geometry and boundary conditions of the simulation is taken from an early benchmark based on helium distribution experiments performed in the GARAGE facility at CEA [16, 17] and are identical to previous analysis [5]. The domain has a size of 3 m times 6 m and a ceiling height of 2 m (Fig. 2). As the experiment is symmetric, only one half of the geometry is modeled in order to reduce the computational efforts. The vent located close above the floor level, which was used in the experiment for pressure compensation (vent 1), is modeled as outlet boundary with a counter pressure of 0 Pa and a loss coefficient (l_c) of 0.1. Active venting is simulated through vent 2 with a volumetric flow rate of 50 m³/h. During active venting scenarios, outflow through vent 3 ($l_c = 10$) is possible. The walls are assumed to have a high heat capacity and thus remain at initial temperature of 18 °C. The hydrogen release rate and total amount (0.5 g/s for a duration of 120 s) is identical to the previously analyzed cases in order to be comparable with the previous work. The relevant model definitions are summarized in Fig. 2 (left).

The fluid domain is discretized by means of a hexahedral, block-structured grid with ~250.000 nodes. The mesh resolution is nearly homogeneous except for a refinement within the release trajectory as well as close to the PAR and vent locations (Fig. 2, right). A dedicated grid sensitivity study and model validation was performed based on the GARAGE experiments [5]. Based on the investigated scenario the geometry was slightly adapted by e.g. varying the PAR elevation or adding a generic car mock-up while the other characteristics remain unchanged.

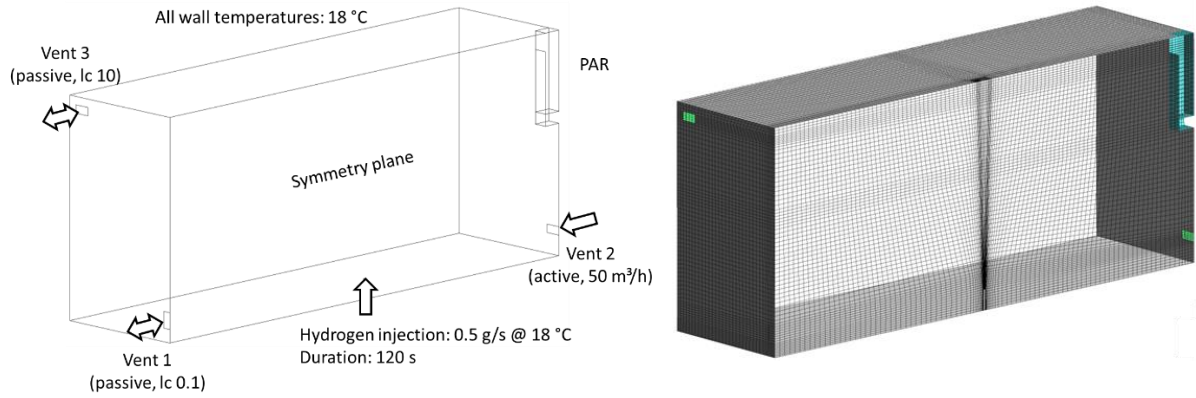

Figure 2: Boundary conditions (left) and numerical grid (right)

3.0 NUMERICAL STUDY

Table 1 gives an overview of the calculations performed during the present study. In a first step, the position of the recombiner has been changed from top to middle and low position (M1 to M3). For the top position, an adiabatic calculation was performed (M4) in order to assess the sensitivity of the simulation results on the thermal boundary conditions. In the second series, the interaction of the recombiner with an active venting device was studied. For this purpose, a scenario including simultaneous operation of both systems was performed (M19) and compared to calculations with separate operation (M14, M16) and without any mitigation measure (M15). In these test cases, the vertical jet injection of hydrogen results in a hydrogen-rich layer underneath the ceiling. In order to assess the impact of the hydrogen distribution, the same arrangement has been repeated for hydrogen release from below a generic car mock-up leading to a more homogeneous hydrogen distribution (M11-M13, M18).

Table 1. Calculation matrix for the present study.

Case no.	PAR position	Wall boundary condition	Vent 1 (passive)	Vent 2 (active)	Vent 3 (passive)	Car
M3	top	18 °C	x	-	-	-
M1	middle	18 °C	x	-	-	-
M2	low	18 °C	x	-	-	-
M4	top	adiabatic	x	-	-	-
M15	no PAR	18 °C	-	-	x	-
M14	no PAR	18 °C	-	x	x	-
M16	top	18 °C	-	-	x	-
M19	top	18 °C	-	x	x	-
M12	no PAR	18 °C	-	-	x	x
M11	no PAR	18 °C	-	x	x	x
M13	top	18 °C	-	-	x	x
M18	top	18 °C	-	x	x	x

3.1 Effect of PAR position

In order to study the effect of PAR position on the hydrogen removal efficiency, 3 simulations with different PAR elevations have been performed, as illustrated in Fig. 3. In top position, the PAR outlet is located directly underneath the ceiling. For the middle position, the PAR is moved downwards for 1/3 of the available height. 1/3 of the available height below the PAR inlet defines the lowest position. In these simulations, vents 2 and 3 remain closed and only pressure compensation through vent 1 is taken into account.

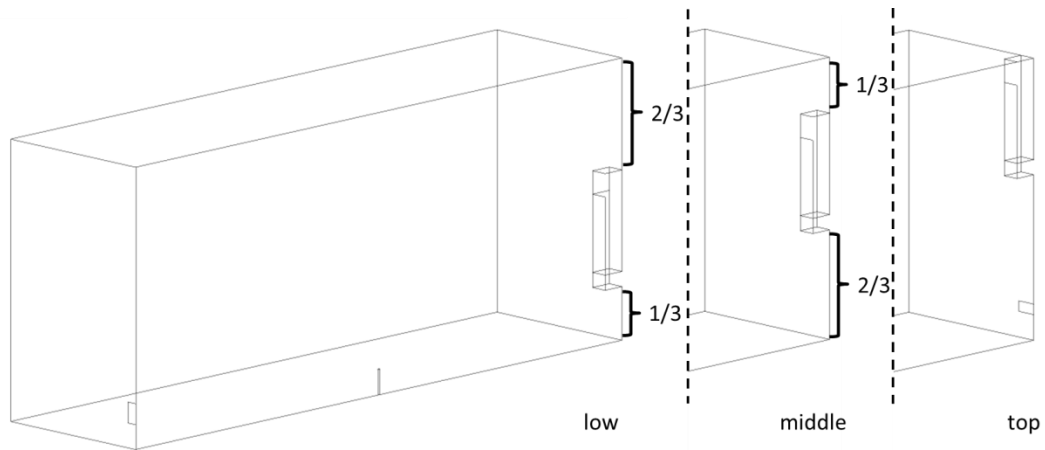

Figure 3: Illustration of PAR positions

Fig. 4 shows a series of snapshots of the hydrogen distribution in the symmetry plane at different simulation time steps. Due to the vertical injection of hydrogen, a hydrogen-rich layer has formed under the ceiling which slowly propagates downwards by diffusion processes, as discussed in [5]. Consequently, the recombiner in top position (M3) is the first to start operation. The hot hydrogen-lean exhaust gas is lighter than the surrounding cold hydrogen-rich gas and forms a layer below the ceiling. By this, the cold hydrogen-rich gas mixture is moving downwards towards the PAR inlet. PAR operation in the lower positions (M1 and M2) has two consequences: On the one hand, hydrogen reaches the PAR inlet at a later time, causing a corresponding start delay of the recombination process. Furthermore, the density difference between areas close to the ceiling and the area below the recombiner is smaller when the PAR is located in lower positions. This effect which is responsible for

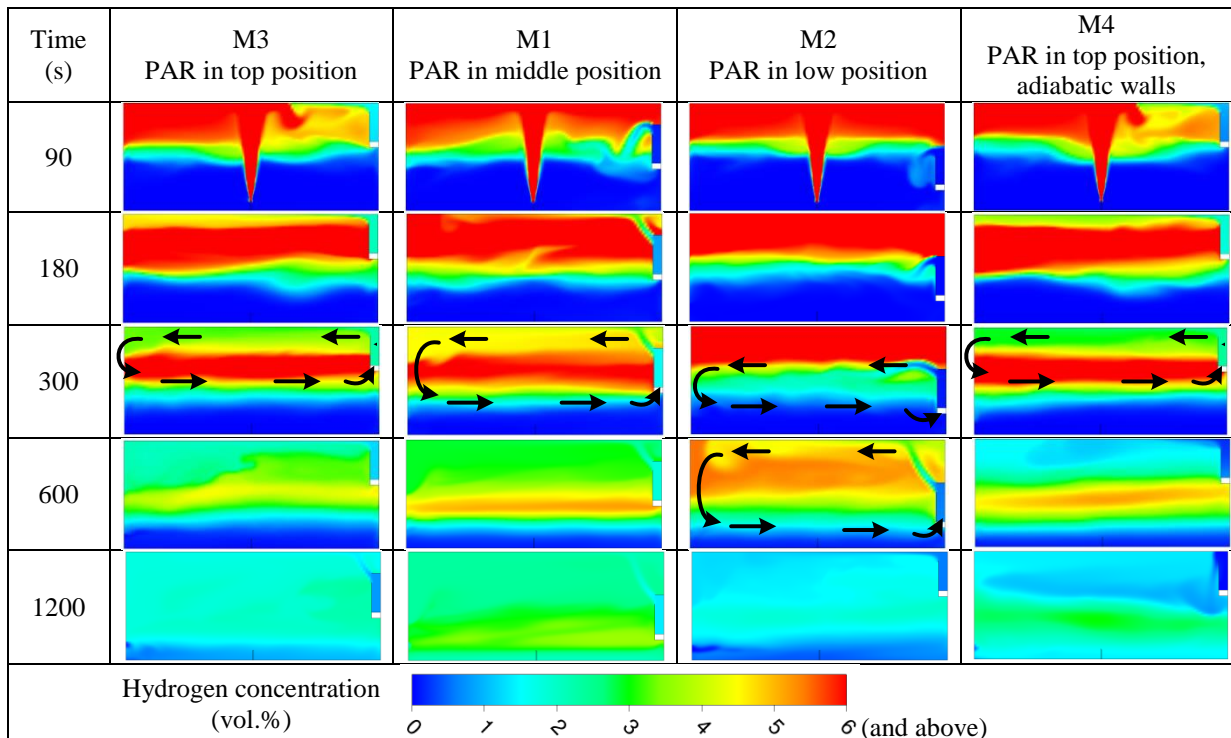

Figure 4: Effect of PAR position: Snapshot series of the hydrogen concentration distribution at the symmetry plane at different time steps

an efficient hydrogen transport towards the PAR inlet is illustrated in Fig. 5. Here, the gas density distribution in the symmetry plane is given for selected time steps. For the PAR in top position (M3), low density values in the ceiling region of approx. 0.9 kg/m^3 are achieved quite early. For the lower PAR positions (M1 and M2), the density difference between ceiling and PAR inlet is less pronounced.

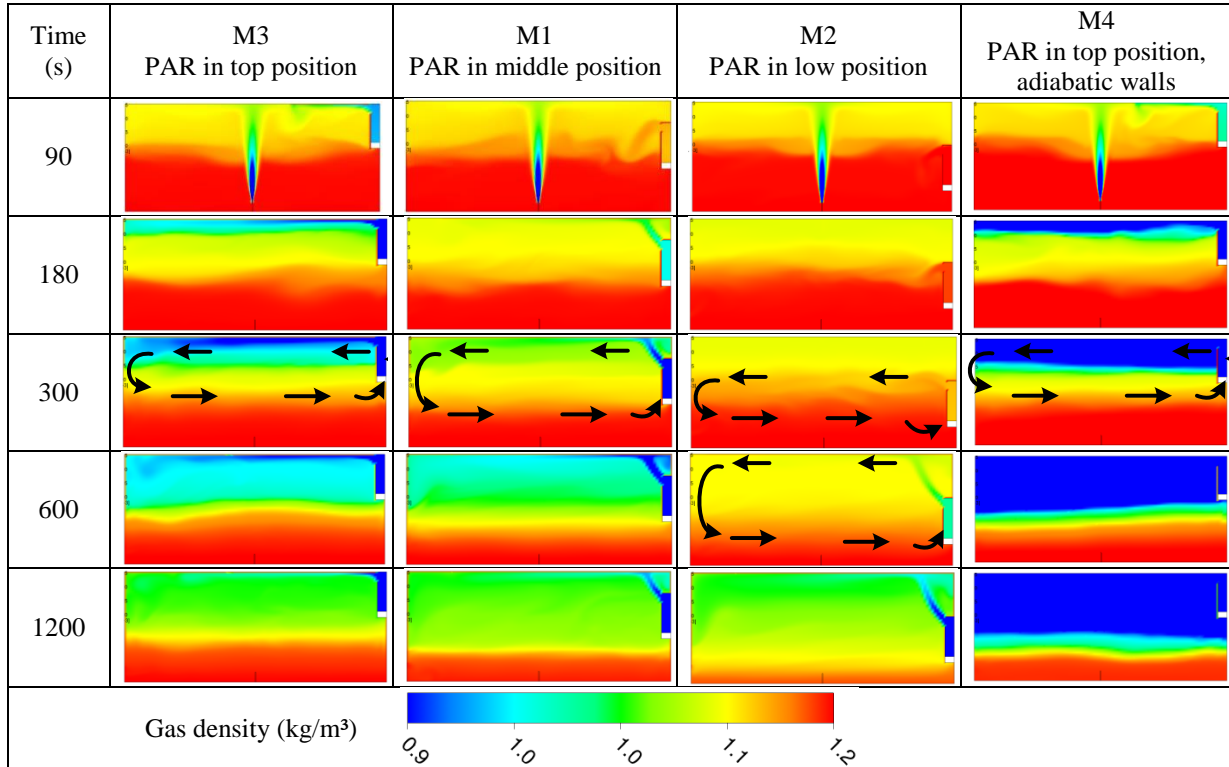

Figure 5: Effect of PAR position: Snapshot series of the gas density distribution at the symmetry plane at different time steps

In order to compare the PAR efficiencies quantitatively, the calculated time histories of the total hydrogen mass inside the garage is given in Fig. 6 (left). During the injection phase (0 s – 120 s), the hydrogen mass is increasing linearly. The further trend of the curves confirms the earlier start-up of hydrogen recombination at the highest PAR position and shows a steeper depletion curve at the same PAR position. In top position (M3), the hydrogen mass is reduced to 50 % of the initial value within approx. 10 min. In middle position (M1), the PAR needs approx. 20 min for the same conversion capacity. Only after more than 30 min, the PAR in lowest position (M2) has achieved a comparable value.

In the perspective of hydrogen safety, the size of the flammable gas volume (hydrogen concentration above 4 vol.%) is of interest. Fig. 6 (right) shows the calculated time histories of the flammable gas volume. Although the total hydrogen amount is continuously reduced (see Fig. 6, left), the flammable gas volume is temporarily increasing immediately after start of the PAR operation. The reason is that the hydrogen concentration of the gas mixture of the hydrogen-rich ceiling layer with the hydrogen-poor outlet gas from the PAR initially is still above the ignition limit. As a consequence, the flammable gas volume increases. While this effect is rather small for the PAR in top position, it is quite significant for the lower positions (M1 and M2). Again, the highest position of the PAR is advantageous and achieves the best performance.

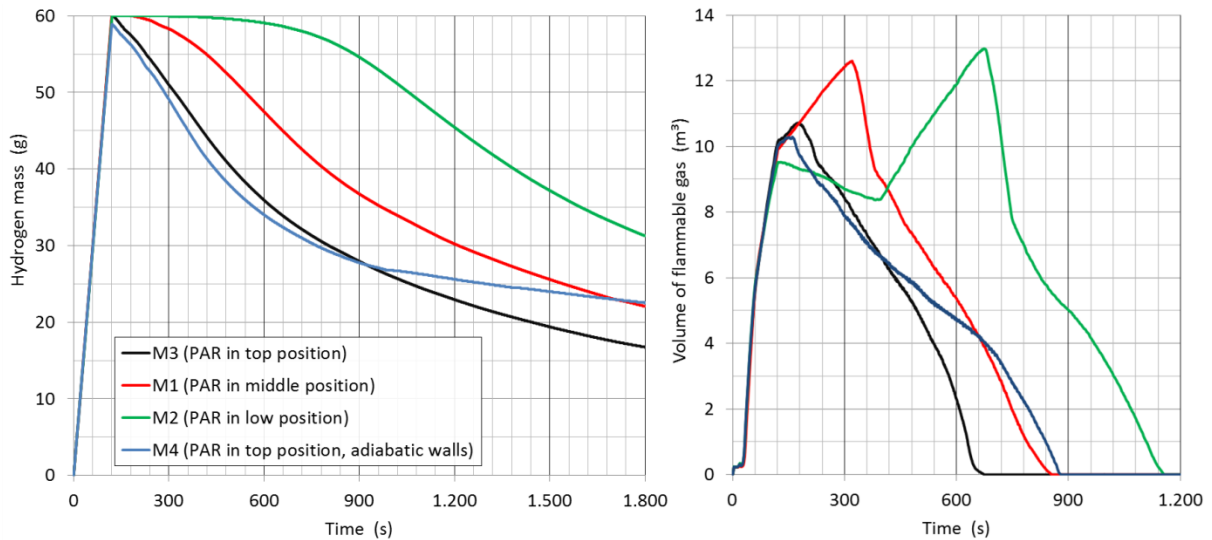

Figure 6: Effect of PAR position: Time history of hydrogen mass inside the garage (left) and volume of the flammable gas cloud (right)

For the most efficient case (PAR in top position) a comparative simulation has been performed with the bounding case of adiabatic walls in order to investigate the sensitivity of the simulation results on the thermal boundary conditions. In this case, the density differences are even more pronounced (Fig. 5, M4, compare with M3), resulting initially in a quicker transport of hydrogen to the PAR inlet. In the later phase however, the thermal stratification prevents the hydrogen located below the PAR inlet elevation to be transported towards the PAR, resulting in a reduction of the conversion capacity and a less efficient consumption of the flammable gas volume (Fig. 6, M4, compare with M3).

3.2 Interaction of PAR and active ventilation, hydrogen-rich ceiling layer

Four scenarios have been simulated in order to assess the interaction of a PAR with an active ventilation system via vent 2 (inlet, at a rate of 50 m³/h) and vent 3 (outlet, see Fig. 2), while vent 1 (near the domain bottom) is closed:

- Active ventilation failure (‘no mitigation’)
- Active ventilation operation (‘active vent’)
- Active ventilation failure compensated by PAR (‘PAR’)
- Active ventilation supported by PAR (‘active vent + PAR’)

Fig. 7 shows a series of snapshots of the hydrogen distribution in the symmetry plane at different simulation time steps. Simulation M15 (‘no mitigation’) shows the stable formation of a hydrogen-rich ceiling layer during the injection phase which propagates slowly downwards through diffusion processes. The effect of the operation of the active vent is given in column M14. Due to the fact that the vent inlet is located above the garage floor and below the layer, and the vent outlet is located inside the ceiling layer, the hydrogen-rich gas is efficiently pushed out of the domain instead of being diluted. In the case of PAR operation (M16), the remaining flammable gas mixture is located in the center of the garage around the elevation of the PAR inlet. Due to the already discussed thermal stratification, PAR operation directly shifts the hydrogen-rich layer downwards while at the same time diluting the flammable cloud.

The combined operation of PAR and active venting shows characteristic phenomena of both measures (M19). On the one hand, we observe the PAR-induced downward propagation of the flammable gas layer. At the same time, the active ventilation pushes hydrogen-lean gas from the PAR exhaust out of the confinement.

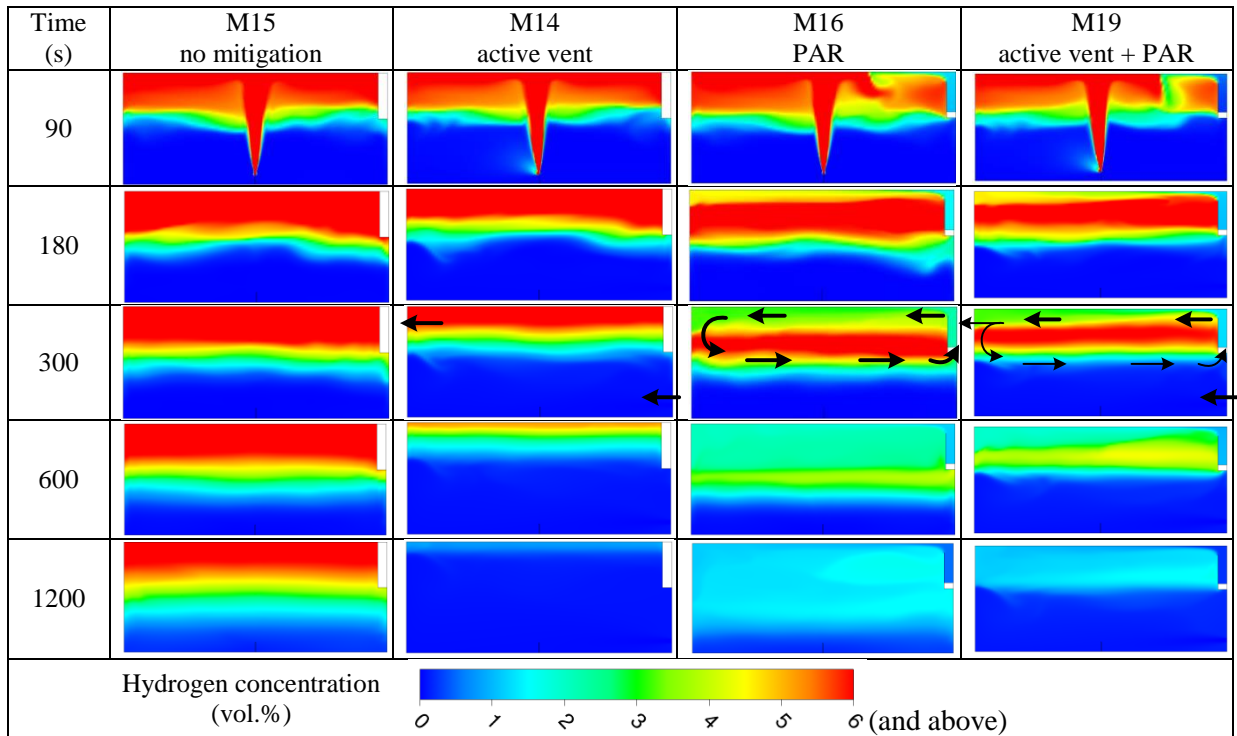

Figure 7: Interaction of PAR and active ventilation (hydrogen-rich ceiling layer): Snapshot series of the hydrogen concentration distribution at the symmetry plane at different time steps

Quantitative comparison of the different simulations shows that the active venting is most effective in reducing the amount of hydrogen (Fig. 8, left). 10 min after start of the injection, the total hydrogen mass of approx. 50 g is reduced to approx. 15 g (M14). In the same time, the PAR achieves only a reduction to 30 g (M16). Surprisingly, the parallel operation of PAR and active venting (M19) reduces the venting efficiency when compared to venting alone. Obviously, the competition of venting operation (pushing hydrogen-rich gas upwards towards the outlet vent) and PAR operation (moving hydrogen-rich gas downwards towards the PAR inlet) leads to a less efficient hydrogen mass reduction inside the garage, as mostly hydrogen-lean PAR exhaust gas is vented from the domain.

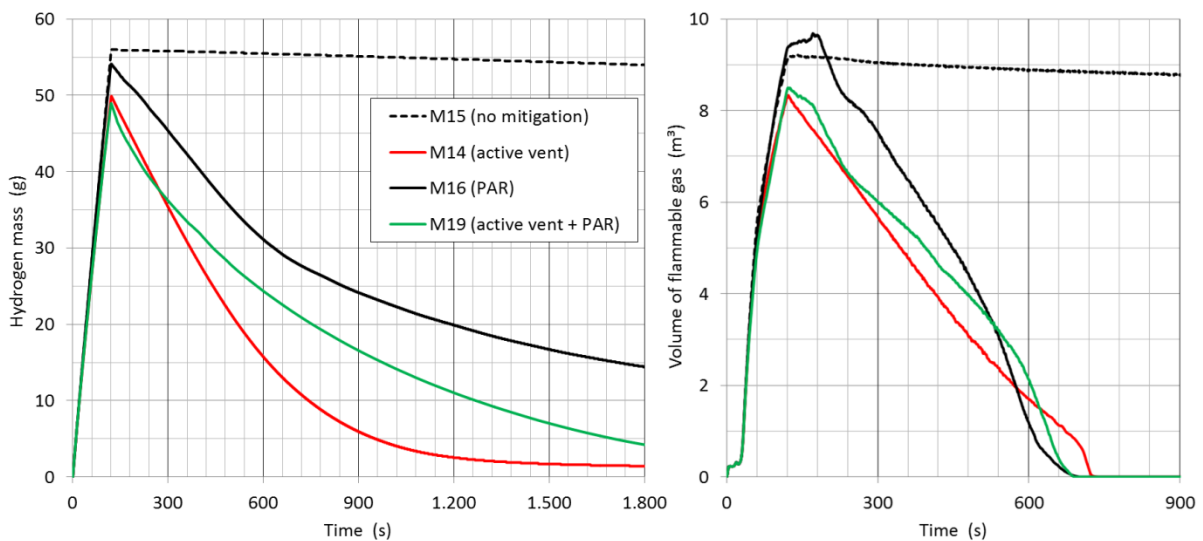

Figure 8: Interaction of PAR and active ventilation (hydrogen-rich ceiling layer): Time history of hydrogen mass inside the garage (left) and volume of the flammable gas cloud (right)

However, the interaction of PAR and active venting doesn't affect the reduction of the flammable gas volume (Fig. 8, right). In all three mitigation scenarios, the flammable gas volume inside the garage is completely removed between 680 s and 720 s after hydrogen injection starts. Obviously, the less efficient hydrogen venting is compensated by the mixing process induced by the PAR which causes effective dilution of the gas mixture.

3.3 Interaction of PAR and active ventilation, homogeneous hydrogen distribution

The former scenarios have treated a vertical hydrogen jet release leading to the formation of a hydrogen-rich ceiling layer inside the garage. However, a diffuse hydrogen release e.g. from underneath a car would lead to a more homogeneous distribution. This case has been investigated by introducing an obstacle in the shape of a car to the numerical domain. The remaining boundary conditions are identical with the aforementioned simulations.

Fig. 9 shows the familiar series of snapshots of the hydrogen distribution in the symmetry plane at different simulation time steps (to be compared with Fig. 7). Case M12 (no mitigation) illustrates the more homogeneous hydrogen distribution compared to the corresponding case M15 (see Fig. 7). Consequently, the maximum hydrogen concentration after the injection phase is below the values for the corresponding former case. For the three mitigated scenarios, similar characteristics as in the corresponding cases can be observed: During active venting through the upper opening, the remaining flammable gas mixture is accumulating under the ceiling (M11) while PAR operation moves the flammable gas to the car level (M13). Simultaneous operation of both devices results in a temporarily accumulation of flammable gases at an intermediate level approx. at the PAR inlet (M18).

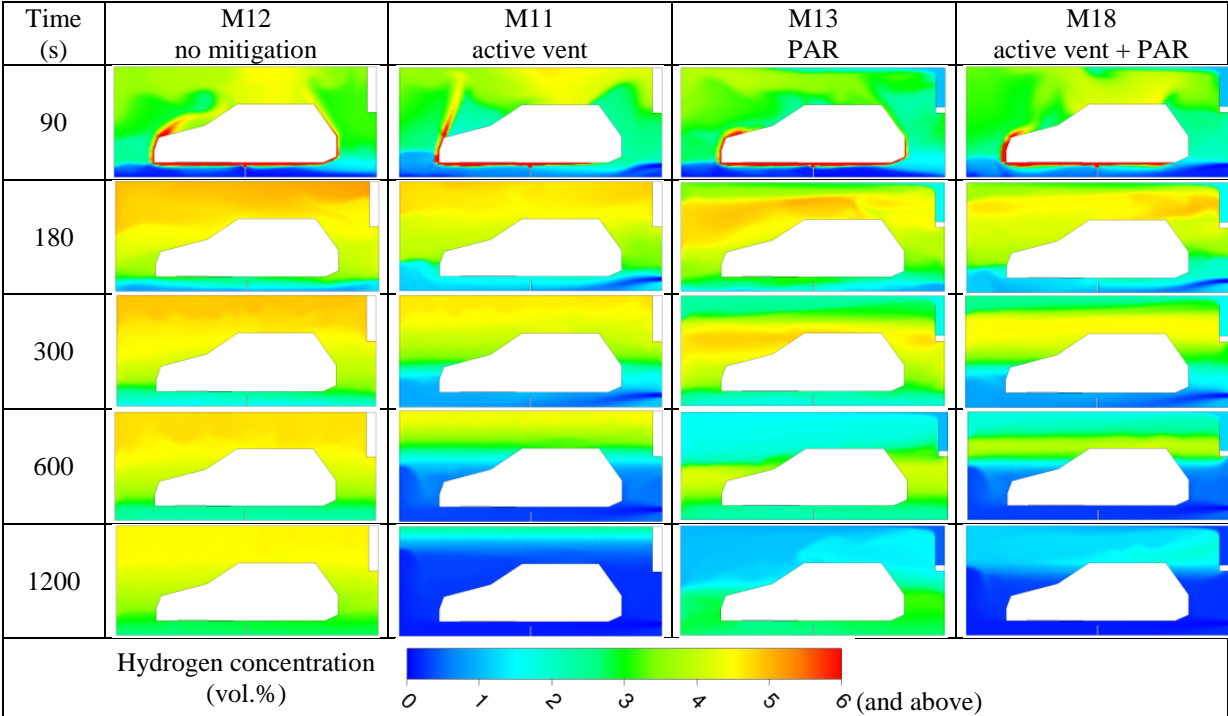

Figure 9: Interaction of PAR and active ventilation (homogeneous hydrogen distribution): Snapshot series of the hydrogen concentration distribution at the symmetry plane at different time steps

The mitigation efficiencies of the investigated scenarios are compared in Fig. 10. Again, active venting is significantly faster removing hydrogen from the domain compared to hydrogen conversion by PAR operation alone (Fig. 10, left). Compared to the case of a hydrogen-rich ceiling layer (see Fig. 8), both devices need approx. 50% more operation time to achieve similar removal capacity. This may be attributed to the advantageous situation in the former case where most of the hydrogen was already accumulated in a ceiling layer close to the outlet vent. Simultaneous operation of both systems shows

a different behaviour as before. This time, PAR operation supports active ventilation, especially in the first 900 s of the scenario (M18).

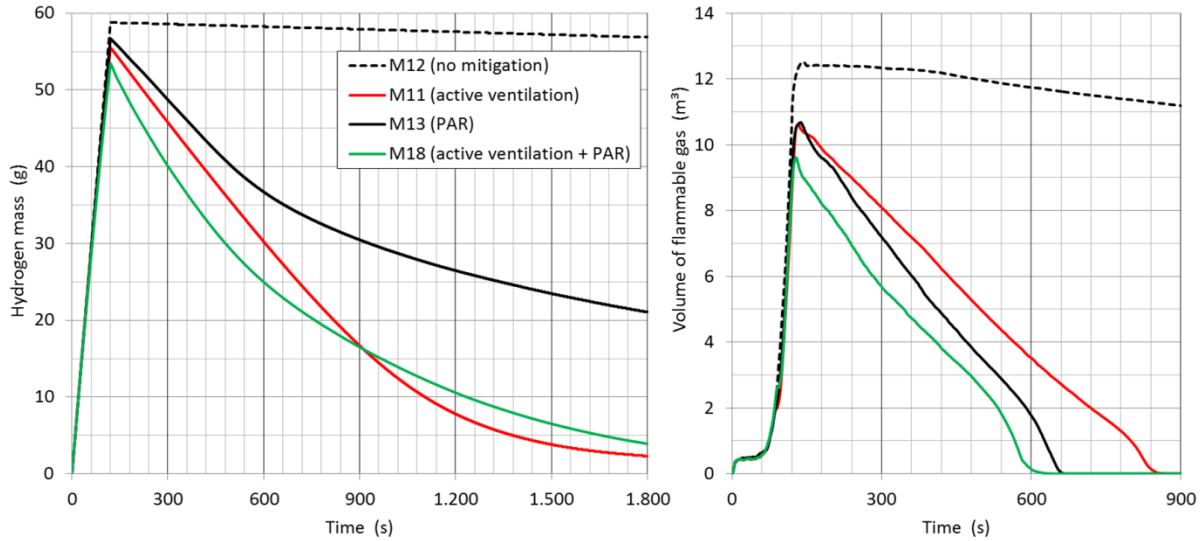

Figure 10: Interaction of PAR and active ventilation (homogeneous hydrogen distribution): Time history of hydrogen mass inside the garage (left) and volume of the flammable gas cloud (right)

Due to the more homogeneous hydrogen distribution inside the garage, the initial overall flammable volume is significantly higher compared to the case with the ceiling layer (Fig. 10, right). This time, the PAR is more efficient removing the flammable gas mixture (M13) compared to case M16. In simultaneous operation (M18), PAR and active venting complement each other enhancing the overall efficiency even further.

4.0 SUMMARY AND CONCLUSIONS

Passive auto-catalytic recombiners (PARs) have the potential to be used in the future as mitigation devices inside confined areas for the conversion of accidentally released hydrogen into water. In the present study, the sensitivity of PAR operation for changing boundary conditions has been investigated by means of CFD simulations. For this purpose, different hydrogen release scenarios inside a prototypical car garage have been calculated. The numerical approach to simulate buoyancy driven flows as well as PAR operation in a CFD environment is well validated against numerous experiments at different scales.

In a first step, the vertical position of the PAR and the thermal boundary conditions of the garage walls have been modified. Furthermore, different hydrogen release modes have been simulated, which result either in a hydrogen-rich layer underneath the ceiling or in a homogeneous hydrogen distribution inside the garage. Finally, the interaction of active venting and PAR operation has been investigated.

Under the given boundary conditions, the optimum PAR location is close underneath the garage ceiling. In this position, the PAR starts operation quickly and promotes the gas mixing process quite efficiently. In case of a failure of the active venting system, the PAR efficiently reduces the flammable gas volume for both stratified and homogeneous distribution. However, depending on the thermal boundary conditions (here: adiabatic walls) the induced density gradient may lead to a thermal stratification preventing hydrogen being transported towards the PAR inlet.

Generally, active venting as well as PAR operation may efficiently remove hydrogen from the closed domain. In a more homogeneously distributed hydrogen atmosphere, PAR and active venting may even complement each other enhancing the overall efficiency even further. However, the simulation

results show that the combined operation of active venting and PAR may reduce the overall efficiency of hydrogen removal if a thermal stratification of hydrogen-lean gas is formed below the ceiling which prevents hydrogen-rich gas to be vented. Consequently, a well-matched arrangement of both safety devices is required in order to optimize the overall efficiency. The presented CFD-based approach is an appropriate tool to support the assessment of the efficiency of PAR application for plant design and safety considerations with regard to the use of hydrogen in confined areas.

By means of appropriate venting the whole domain can be involved in the mixing process, while the buoyant circulation induced by the PAR only affects the gas volume above the PAR inlet elevation. For stand-alone PAR operation, at least two PARs are required (one located at the top, one at the bottom) to achieve both, a quick start of the depletion process as well as a complete buoyant mixing of the domain.

REFERENCES

1. Molkov, V., Safety objectives, phenomena and consequences map, Hyindoor Final Dissemination Workshop, December 11, 2014.
2. Jäkel Ch., Kelm St., Reinecke E.-A., Verfondern K., and Allelein H.-J., Validation strategy for CFD models describing safety-relevant scenarios including LH₂/GH₂ release and the use of passive auto-catalytic recombiners, *International Journal of Hydrogen Energy*, **39**, 2014, pp. 20371-20377.
3. Liang Z. et al., Status report on hydrogen management and related computer codes, NEA/CSNI/R (2014) 8.
4. Reinecke E.-A., Bentaib A., Kelm S., Jahn W., Meynet N., and Caroli C., Open issues in the applicability of recombiner experiments and modeling to reactor simulations, *Progress in Nuclear Energy*, **52**, 2010, pp. 136-147.
5. Reinecke E.-A., Kelm S., Jahn W., Jäkel C., Allelein H.-J., Simulation of the efficiency of hydrogen recombiners as safety devices, *International Journal of Hydrogen Energy*, **38**, 2013, pp. 8117-8124.
6. ANSYS, Inc., ANSYS CFX-Solver theory guide and solver modeling guide, Release 15, Canonsburg, October 2013.
7. Kelm S., Ritterath M., Prasser H.-M., Allelein H.-J., Application of the MiniPanda test case 'erosion of a stratified layer by a vertical jet' for CFD validation, Proc. OECD/NEA and IAEA Workshop on Experiments and CFD Codes Application to Nuclear Reactor Safety (CFD4NRS-5), Daejeon, Korea, September 9-13, 2012.
8. Kelm S., Lehmkuhl J., Jahn W., Allelein H.-J., A comparative assessment of different experiments on buoyancy driven mixing processes by means of CFD, Proc. 7th European Review Meeting on Severe Accident Research (ERMSAR-2015), Marseille, France, March 24-26, 2015.
9. Kapulla R., Kelm S., Mignot G., Paranjape S., Paladino D., Experimental and numerical results for the erosion dynamics of a vertical helium-air jet interacting with a helium rich layer, Proc. International Congress on Advances in Nuclear Power Plants (ICAPP 2015), Nice, France, May 3-6, 2015.
10. Andreani M., Kelm S., Simulation of mixing induced by a hot PAR exhaust plume, Proc. 20th Int. Conf. on Nuclear Engineering ICONE-20, Anaheim, CA, USA, July 30-August 3, 2012.
11. Casey M., Wintergerste T., ERCOFTAC Special interest group on quality and trust in industrial CFD – best practice guidelines”, ERCOFTAC, 2000.
12. Menter F. et al., CFD best practice guidelines for CFD code validation for reactor safety applications, EU-ECORA Project, EC Contract No FIKS-CT-2001-00154, 2001.
13. Böhm J., Modelling of the processes in catalytic recombiners, Report Forschungszentrum Juelich (Energy Technology) 61 (2006).

14. Kelm S., Jahn W., Reinecke E.-A., Schulze A., Passive auto-catalytic recombiner operation - validation of a CFD approach against OECD-THAI HR2-test, Proc. OECD/NEA & IAEA Workshop on Experiments and CFD Codes Application to Nuclear Reactor Safety (XCFD4NRS), Deajon, South Korea, September 9-13, 2012.
15. Reinecke E.-A., Kelm S., Allelein H.-J., Validation of the PAR code REKO-DIREKT against large scale experiments performed in the frame of the OECD/NEA-THAI project, Proc. 7th European Review Meeting on Severe Accident Research (ERMSAR-2015), Marseille, France, March 24-26, 2015, paper no. 060.
16. Gupta S., Brinster J., Studer E., Tkatschenko I., Hydrogen related risks within a private garage: Concentration measurements in a realistic full scale experimental facility, *International Journal of Hydrogen Energy*, **34**, Issue 14, 2009, pp. 5902-5911.
17. Venetsanos A.G., Toliás I., Baraldi D., Benz S., Cariteau B., Garcia J., Hansen O.R., Jaekel C., Ledin S., Middha P., Papanikolaou, E., HySafe Standard Benchmark Exercise SBEP-V21: Hydrogen release and accumulation within a non-ventilated ambient pressure garage at low release rates, Proc. 4th Int. Conf. on Hydrogen Safety (ICHS-4), San Francisco, CA, September 12-14, 2011, paper no. 200.